

American National Standard
for Telecommunications –

Numbering of Signalling Point Codes

1 Scope, Purpose, and Application

This chapter describes the numbering scheme of signalling point codes for ANSI Common Channel Signalling (CCS) System Number 7 (SS7) networks. The technical aspects of the signalling networks are specified in Chapter T1.111.5.

The network structure described in Chapter T1.111.5 makes possible a clear division of responsibility for signalling network management, and allows numbering plans of signalling points of the international network and the different national networks to be independent of one another.

It is also noted that the point code is intended to be processed within the Message Transfer Part (MTP) of each signalling point or signalling transfer point, so that there is no direct relationship to the telephone, data, or ISDN numbering.

1.1 Definitions

The following terms are used in this chapter:

1.1.1 ANSI-41 networks: For the purpose of this document, ANSI-41 networks are mobile networks using TIA/EIA-41 as the Mobile Application Part for intersystem interfaces.

1.1.2 CCS Group: A signalling point or group of signalling points that are not part of a CCS network but are commonly owned or administered is referred to as a CCS Group. A CCS Group is identified as a group of signalling points without any STP (i.e., none of the nodes in the group have STP functionality).

1.1.3 CCS Network: A set of signalling points (including STPs), using out-of-band signalling, that are operated, administered, and maintained by the operator of the network.

1.1.4 Code Administrator: The entity authorized by T1 and the companies supporting T1 to administer signalling point code assignments according to the guidelines set forth in this document. The Code Administrator administers the network codes and point code blocks.

1.1.5 Large CCS Network: A large CCS network is a CCS network that provides signalling for more than 75 signalling points (operated, administered, and maintained by the operator of the network) in the first year of operation and at least 150 signalling points (belonging to the network) by the end of the first 5 years of operation. Also, it must have at least 6 network elements providing STP functionality in the first year of operation, and at least 12 network elements providing STP functionality by the end of 5 years of operations.

1.1.6 Network Administrator: Administrator of a CCS network or CCS group. The administrator of a CCS network or CCS group, who is directly affiliated with the CCS network or CCS group, serves as the contact between the Code Administrator and the CCS network or CCS group in regards to ANSI

T1.111.8-2001 (T1.111a-2002)

signalling point codes. It is the responsibility of the Network Administrator to keep the Code Administrator informed of any information changes regarding information supplied at the time of the code assignment request. The Network Administrator administers the point codes within the network code and point code blocks of its affiliated CCS network or CCS group respectively that have been assigned by the Code Administrator (see A.3.2).

1.1.7 North America: For simplicity of reference in this document, those countries served by the North American Numbering Plan (NANP).

1.1.8 Signalling Point - A node in a signalling network that either originates and receives signalling messages, or transfers signalling messages from one signalling link to another, or both.

1.1.9 Signalling Point Code: A code used to identify a signalling point and processed within the MTP of each signalling point and within users of the MTP.

1.1.10 Small CCS Network: A small CCS network is a CCS network that does not meet the criteria of being a large CCS network.

1.2 Abbreviations & Acronyms

ANSI	American National Standards Institute
CCS	Common Channel Signalling
EIA	Electronic Industries Association
ISDN	Integrated Services Digital Network
MTP	Message Transfer Part
NANP	North American Numbering Plan
NID	Network Identification
SPC	Signalling Point Code
SS7	Signalling System No. 7
STP	Signalling Transfer Point
TIA	Telecommunications Industry Association

2 Format of ANSI Signalling Point Code

2.1 Binary Code Format

Signalling points are identified by a 24-bit binary code that is called a signalling point code or point code. A point code should be assigned to each signalling point that belongs to an ANSI CCS network or CCS group of signalling points.

T1.111.8-2001 (T1.111a-2002)

2.2 Fields of a Point Code

A point code consists of three fields as indicated in Figure 1/T1.111.8. The most significant field of 8 bits identifies a signalling network. The next field of 8 bits identifies a cluster in a specific network. The least significant field of 8 bits identifies a member (i.e., signalling point) of a specific cluster (see 7.4 of T1.111.5 for information regarding network structure and routing).

NOTE - An extension to this general scheme is used to identify small CCS networks and CCS groups (see 3.3).

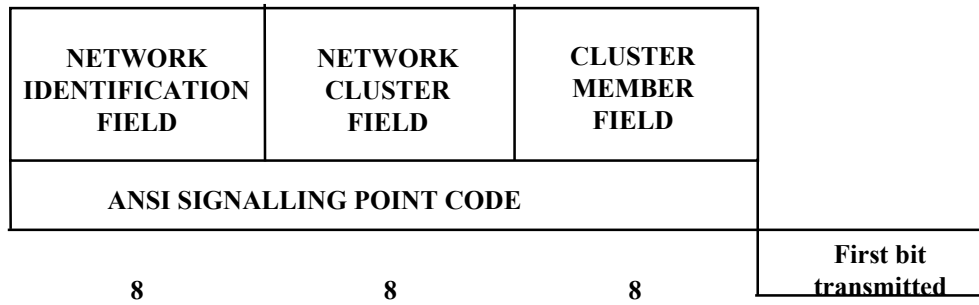

Figure 1/T1.111.8 - Format for ANSI signalling point codes

2.3 Available Number of Point Codes

The system of network codes will provide for $249 + (4 \times 255) = 1269$ network codes. The system of signalling point codes will provide for $(249 \times 256 \times 256) + (5 \times 255 \times 256) = 16,644,864$ signalling point codes.

3 Numbering of Signalling Points in ANSI Networks

3.1 Assignment Categories

United States CCS (SS7) networks and CCS groups, other CCS networks and CCS groups utilizing the NANP and ANSI-41 CCS networks and CCS groups outside of North America may be assigned a network code or point code block and shall follow the guidelines in Annex A.

The Code Administrator shall be responsible for assigning and administering the following categories of codes:

- a) *Network codes* from the Network Identification Field (NID) for large networks;
- b) *Cluster codes* from NID 1 through 4 for small networks;
- c) *Point code blocks* from NID 5 for CCS Groups (blocks of signalling point codes from the cluster member field); and
- d) *Cluster codes and point code blocks* from NID 6 for ANSI-41 CCS networks and CCS groups outside of North America.

T1.111.8-2001 (T1.111a-2002)

Guidelines for the assignment and administration of network codes and signalling point code blocks are provided in Annex A.

3.2 Unused Code

The network code of 0 (0000 0000) shall not be used. When the network cluster field is used to identify small networks, the network cluster code of 0 (0000 0000) shall not be used. When the Cluster Member Field is used to identify a CCS Group, the Cluster Member code of 0 shall not be used.

3.3 Small Network and Group Codes

Five of the network identification field codes, namely 1, 2, 3, 4, and 5 are reserved for assignment to small CCS networks and CCS groups. For network codes 1, 2, 3, and 4, their associated network cluster field codes shall be assigned as network codes for small networks. For network code 5, the network cluster and cluster member fields shall be partitioned into signalling point code blocks that shall be assigned to CCS groups that are not eligible for a network code assignment. For network code 5, a network cluster code is associated with each State, Province, or Territory in the United States and Canada. Similarly, specific network clusters are associated with the Caribbean, Atlantic, and Pacific countries, and territories within North America. Point code blocks from the respective network cluster codes are assigned to CCS groups according to the physical locations of the signalling points in the CCS groups.

3.4 Code for ANSI-41 CCS Networks and Groups Outside North America

Network identification field code 6 is reserved for assignment outside North America to ANSI-41 CCS networks and CCS groups.

3.5 Test Code

The network code of 229 (1110 0101) is assigned by T1S1 for testing.

3.6 Reserved Code

The network code of 255 (1111 1111) is reserved for future use.

4 General Principles

4.1 A large CCS network may be assigned a network code based upon the applicant's compliance with the guidelines in normative Annex A. A secondary network code may be assigned to a large CCS network provided that the applicant satisfies the criteria in Annex A

NOTE - A large CCS network is not eligible for more than two network codes.

T1.111.8-2001 (T1.111a-2002)

A small CCS network may be assigned up to four “small” network codes upon request and more than four based on the applicant’s compliance with the guidelines in Annex A. A CCS Group will be assigned the exact number of signalling point code blocks (four codes per block) requested based on the applicant’s compliance with the guidelines in Annex A (see A.1).

4.2 Lists of network codes and signalling point code blocks are maintained by the Code Administrator. Once a network code or signalling point code block has been assigned to a CCS network or CCS group, respectively, the assignment of point codes to individual signalling points is the responsibility of that network or group. (See Chapter T1.111.5, “Signalling Network Structure,” for information on routing, addressing, and examples of individual point code assignments.)

4.3 In the case where small networks are assigned more than one network code and the NIDs of the network codes have different values, the Network Administrator shall use point codes having the same value in the NIDs to address a mated pair of STPs. This requirement is justification for a small network to request additional cluster codes to satisfy this condition.

5 Shared Clusters and Groups

If through merger, acquisition, divestiture, joint venture, or partnership split, a signalling point(s) or cluster(s) now belongs to a CCS network or CCS group different from the one originally assigned the large network code, small network code, or point code block, the new CCS network or CCS group may retain the point code(s) or cluster(s) temporarily, provided that the network connections do not change due to the reorganization (e.g., other networks will not need to change their routing). This would allow a network element to retain its original point code and remain in operation when acquired by a different CCS network or CCS group as a result of any of the mentioned events. In this case, the Code Administrator shall be notified and will maintain assignment information for both CCS networks or CCS groups about that specific point code(s). The CCS network or CCS group originally assigned the network code or point code block is still considered to be the assignee of the point codes and has primary responsibility for coordinating the sharing arrangement. This allowance does not affect the method by which the Code Administrator assigns point codes. (Allowing network reconfiguration when network elements retain their original SPCs and move to a different CCS network or CCS group is for further study.)

When the point codes are no longer used by the acquired CCS network or CCS group in a shared arrangement (i.e., as a result of point code change), the Code Administrator shall be informed and the point codes shall be returned to the full control of and use by the original assignee.

Annex A
(normative)

A CCS Code Administration Guidelines

A.1 Eligibility for CCS code assignment

A.1.1 A CCS network (defined in 1.1) is a set of signalling points with an STP or STP functionality using out-of-band signalling that are operated, administered, controlled, and maintained by the operator of the network.

A.1.2 Any United States CCS (SS7) network, other CCS networks utilizing the North American Numbering Plan (NANP), or ANSI-41 CCS network outside of North America may be assigned a network code.

A.1.3 A single signalling point or group of signalling points without a STP or STP functionality (referred to as a CCS group) is not considered a network and will not be eligible for a unique network code assignment. These CCS groups will instead be eligible for assignment of a signalling point code block(s).

A.1.4 Any United States CCS group, other CCS group utilizing the North American Numbering Plan, or ANSI-41 CCS group outside of North America is eligible for point code block assignment.

A.1.5 Only CCS networks and CCS groups will be assigned network codes and signalling point code blocks, respectively. Firms or groups of firms that are associated with CCS networks or CCS groups (e.g., own, share, or lease) are not eligible for network code or signalling point code block assignment. The intent is to assign network codes or signalling point code blocks to CCS networks or CCS groups, and not to a firm or group of firms associated with a CCS network or CCS group.

A.1.6 XXX

All applicants shall follow the guidelines in this Annex.

A.2 Administration of CCS code assignments

A.2.1 General administration principles

A.2.1.1 There shall be no advance reservation process for code assignments. Codes shall be assigned when the indication of building and operating a CCS network or CCS group is given to the Code Administrator.

T1.111.8-2001 (T1.111a-2002)

A.2.1.2 The plan is to assign unique network codes and signalling point codes that shall be used by CCS networks or CCS groups anywhere in the United States, North America, or by ANSI-41 CCS networks outside of North America. Signalling point code blocks assigned to CCS groups shall share a network code and network cluster codes, but the signalling point codes assigned shall be unique. Once a network code or point code block is assigned, the Code Administrator is not responsible for assigning the point codes to SPs or STPs within a network or group.

A.2.1.3 The network code of 0 shall not be used. The network code of 255 is reserved for future use. The network codes 1, 2, 3, and 4 are reserved for small network code assignments using the network cluster field. The network code 5 is reserved for assignment of signalling point code blocks to CCS groups. The network code 6 is reserved for assignment outside of North America to ANSI-41 CCS networks and CCS groups.

A.2.1.4 Large networks shall be assigned network codes starting with 254 and decrementing. Small networks shall be assigned network codes starting with network identification field code 1 and cluster field code 1 (small network code 1- 1), and incrementing. When using the network cluster field to assign network codes, the network cluster code of 0 shall not be used.

A.2.1.5 These guidelines authorize the Code Administrator to assign ANSI CCS point codes to ANSI-41 CCS networks and CCS groups that are outside North America. Network identification field code 6 has been reserved for this purpose

A.2.2 Criteria for large network code assignment

A.2.2.1 A CCS network shall be assigned a large network code if all of the following conditions are met:

- (a) The applicant certifies that its network includes at least 75 signalling that are or will be operational within a year.
- (b) The applicant certifies that its network includes at least 6 network elements providing STP functionality that are or will be operational within the first year.
- (c) The applicant certifies that its network includes at least 150 signalling points that are or will be operational by the end of 5 years.
- (d) The applicant certifies that its network includes at least 12 network elements providing STP functionality that are or will be operational by the end of 5 years.

A.2.2.2 Other CCS networks not satisfying the conditions described above shall be assigned a small network code (see A.2.3). CCS groups are not eligible for a network code assignment and shall be assigned signalling point code blocks (see A.2.4).

A.2.2.3 The first network code assigned shall be called the "primary" code. Additional network codes shall be called "supplemental" codes.

T1.111.8-2001 (T1.111a-2002)

A.2.2.4 A large CCS network has the potential of being assigned only one supplemental code, based on a listing of signalling points identified in the applicant's request for a supplemental code, to accommodate exhaust of the primary code.

A.2.3 Criteria for small network code assignment

A.2.3.1 CCS networks not satisfying all the criteria established for large network codes in A.2.2.1 shall be assigned a small network code.

A.2.3.2 A small CCS network shall have the potential of being assigned up to four small network codes on the initial request, and more than four based on compliance with the requirements described below.

A.2.3.3 A valid small network code request shall include:

- The number of signalling points;
- The number of network elements providing STP functionality;
- The number of cluster codes requested; and
- Certification that the network will be operational within one year.

More than four small network codes will be assigned providing that the Network Administrator provides the aforementioned items and justifies the need for signaling point(s) in new clusters, instead of the existing cluster. Such needs may include, but are not limited to:

- Existing cluster(s) must be split because of capacity or survivability constraints including but not necessarily limited to traffic, port translations, or numbering such that the existing STP pair is expected to exhaust within 3 years.
- A new signalling point is being installed; however, it is expected to be re-homed within 5 years on a STP pair that will have a different network identification cluster code.
- Network configuration, routing, or screening in the requesting or adjacent networks will be simplified if some signaling points within previously assigned clusters are placed in a new cluster or if a new signalling point is installed in a cluster separate from those previously assigned.
- Additional codes are needed to satisfy the requirement that a mated STP pair must be assigned point codes from the same NID (see 4.3).

Cluster member code 0 is reserved for addressing STPs; however, a STP is not required to have an address with cluster member code 0.

NOTE - Clause 2.2.3D of T1.111.4 provides information regarding the encoding of member code 0 in the network cluster member field.

A.2.4 Criteria for point code block assignment

A.2.4.1 CCS groups are not eligible for a network code assignment (i.e., no signalling point with transfer functionality) and shall be assigned signalling point code blocks for their use.

A.2.4.2 A CCS group may be assigned any number of signalling point code blocks based on compliance with the requirements described below.

A.2.4.3 A valid signalling point code block request shall justify the need for each supplemental point code block request. A CCS group will be assigned the exact number of signalling point code blocks required based on the number of signalling points being placed into service within one year of the request and the physical location of each signalling point as described below.

A.2.4.4 A signalling point code block contains four contiguous signalling point codes. For network code 5, a network cluster code is associated with each State, Province, or Territory in the United States and Canada. Similarly, specific network cluster are associated with the Caribbean, Atlantic, and Pacific countries, and territories within North America. Point code blocks from the respective network cluster codes are assigned to CCS groups according to the physical locations of the signalling points in the CCS groups. Within each network cluster code associated with a particular State, Province, and Territory, signalling point code blocks shall be assigned starting with the first block of signalling points (signalling point codes 5-X-0 through 5-X-3) and incrementing. Cluster member code zero (0) is reserved for addressing signaling transfer points, therefore those point code values (including signalling point code blocks [Network Identifier 5-X-4 through 5-X-73] beyond cluster 13) shall not be assigned to signalling points without the transfer function.

NOTE - A CCS group by definition does not have a signalling point with the transfer function. Clause 2.2.3D of T1.111.4 provides additional information regarding the encoding of member code 0 in the network cluster member field.

When the last point code block within a network cluster code for a state, province, or territory or North American country using the NANP has been assigned, the Code Administrator shall associate the next unused network cluster code of network code 5 with the state, province, or country using the NANP.

NOTE - A provider that started initially as a CCS group and later decides to introduce a signalling point with STP functionality shall request an network code, large or small (based on the appropriate assignment criteria), in addition to its existing codes. A CCS group point code block shall not be assigned if the group of signaling points has a signalling point with transfer functionality.

A.2.5 Specific and Additional Criteria and Procedures for CCS Networks and CCS Groups Outside of North America Using ANSI-41

A.2.5.1 Applicants shall not apply for nor be assigned large network codes.

A.2.5.2 Applicants will adhere to all conditions, criteria, and procedures as detailed for North American networks in other sections of this document, when applying for a network code or point code block.

T1.111.8-2001 (T1.111a-2002)

A.2.5.3 ANSI-41 CCS networks or CCS groups outside of North America will be assigned small network codes or point code blocks respectively, only from NID 6.

A.2.5.4 Network codes and point code blocks that are assigned under the conditions, criteria, and procedures contained in this Annex are subject to the same reclamation procedures as detailed in this document for North American networks.

A.2.5.5 An ANSI-41 CCS network outside of North America that spans multiple countries (i.e., a multi-national network or group) is treated as a single network. Applicants shall not apply for nor shall the Code Administrator assign network codes on a per country basis.

A.2.5.6 The following additional conditions, criteria, and procedures apply to code applicants operating ANSI-41 CCS networks and CCS groups outside of North America:

- The applicant network must identify itself to the Code Administrator by certifying that it is an ANSI-41-based CCS network or CCS group outside of North America and by providing its full international address.
- The applicant network must identify the country(ies) in which it operates and, in the case of multiple countries, which country(ies) the applied for network code(s) or point code block(s) will be utilized.
- If the criteria for a CCS small network are met, the Code Administrator will make the requested assignment of a small network code from NID 6 starting with cluster 1 in ascending order.
- If the criteria for a CCS group point code block are met, the Code Administrator will make the requested assignment of a point code block from a cluster in NID 6 that the Code Administrator has reserved, starting from cluster 254 in descending order.

A.3 Procedure for requesting a code assignment

A.3.1 It is required that the Network Administrator of the CCS network or CCS group desiring a network code or point code block assignment, respectively, contact the Code Administrator (see A.6).

A.3.2 The Network Administrator of the CCS network or CCS group must submit a completed application form (Contact Code Administrator for Application Form) to the Code Administrator requesting an assignment. When requesting a network code or signalling point code block assignment, the Network Administrator of the CCS network or CCS group must provide an exact corporate name and address, and list all of the firms associated with the CCS network or CCS group. It must also inform the Code Administrator of any previously assigned network codes or signalling point code blocks. Exact spelling, capitalization, hyphenation, and the like are necessary. In addition, the Network Administrator of a CCS group must also inform the Code Administrator of the state, province, territory, or country where each signalling point is physically located. When requesting an assignment, the Network Administrator of the CCS network or CCS group must give some justification for the assignment (see A.2).

A.3.3 The Network Administrator of the CCS network or CCS group must indicate whether it is an ANSI-41 CCS network or CCS group outside of North America (See A.2.5).

A.3.4 Assignments shall be on a first-come, first-served basis. A CCS network requesting an assignment shall be given the next available network code. A CCS group in North America requesting an assignment shall be given the next available signalling point code block of the network cluster code of network code 5 associated with the State, Province, Territory, or North American country using NANP where each signalling point is physically located. An ANSI-41 network outside North America qualifying as a CCS group and requesting an assignment shall be given the next available signalling point code block of the network cluster code reserved for CCS group assignment within NID = 6. The CCS group Network Administrator shall assign point codes to its signalling points based on the association of the network cluster codes of the assigned signalling point code blocks to the states, provinces, or countries using NANP where the signalling points are physically located. See Figure A.1 describing the application process. When a new network code or signalling point code block is assigned, the Code Administrator shall notify T1 (i.e., the Chair of the T1S1.3 Working Group) and provide a written confirmation to the Network Administrator of the CCS network or CCS group.

A.4 Reclaiming assigned codes

A.4.1 Assigned network codes and signalling point code blocks shall remain in effect as long as the CCS network or CCS group is in operation. If a CCS network or CCS group is no longer in operation, the Network Administrator of the CCS network or CCS group agrees to relinquish the codes or signalling point code blocks within 60 days in writing to the Code Administrator. The Code Administrator, upon determining that a network code is no longer in operation, should verify it by attempting to contact the authorized representative for that network and request voluntary return of their code. If no response is received within 60 days or if the entity does not object, the entity is notified that their code is being reclaimed and will become available for reassignment after a 6-month transition period.

A.4.2 Network codes or signalling point code blocks are not transferable from one CCS network or CCS group to another.

A.4.3 If a number of firms merge and a consolidated operation of their CCS networks results, the newly consolidated CCS network may choose which code(s) is to be retained for operation. The Network Administrator shall notify the Code Administrator of such code(s). The code(s) that is not retained shall become available for reassignment after a 6-month transition period. A similar situation involving CCS groups may not require the relinquishing of any assigned signalling point code blocks.

A.4.4 If a number of firms merge and separate network operations are maintained, the Code Administrator shall be notified and the code(s) may be retained by the individual CCS networks. The Code Administrator shall verify with the merged firms that the separate network operations are to be maintained.

A.4.5 A CCS group that was assigned point code blocks before the assignment guidelines were revised to take into account the physical location of signalling points may voluntarily choose to release its currently used point code blocks for reclamation and be assigned new point code blocks based on the physical location of its signalling points. The point code blocks to be reclaimed must be indicated to the Code Administrator and requests for new point code blocks must be submitted to the Code Administrator according to A.3.

A.5 Conservation of codes

Initially only one network code shall be assigned to a large CCS network. Up to four small network codes will be assigned to a small network -- potentially more if justified. The number of signalling point code blocks assigned to a CCS group is dependent on the demonstrated need of the CCS group. It is the responsibility of the Code Administrator to continually monitor the assignment of the network codes and signalling point code blocks, and the potential for their exhaust. The Code Administrator is to inform T1 (i.e., the Chair of the T1S1.3 Working Group) if there is a potential of exhaust and the type of conservation action that has been put into effect.

A.5.1 Conservation of large network codes

If the assignment of codes reaches the 80% level of available large network codes (200 large network codes), then no supplemental codes shall be assigned. If the assignment of codes reaches the 90% level of available large network codes (225 large network codes), then an attempt shall be made to reclaim any supplemental codes assigned. It is expected that the industry would cooperate and voluntarily offer to release minimally used codes. The Code Administrator should negotiate with code assignees to identify such codes for potential release and reassignment.

A.5.2 Conservation of small network codes

If the assignment of codes reaches the 70% level of available small network codes, then the first course of action would be to reserve an additional large network code. If the assignment of large network codes has reached the 80% level, then a large network code shall not be reserved. Instead, the potential of being assigned up to four small network codes at the initial request will be reduced to three. If the assignment of codes reaches the 80% level of available small network codes, then no supplemental codes shall be assigned. If the assignment of codes reaches the 90% level of available small network codes, then an attempt shall be made to reclaim any supplemental code assigned. It is expected that the industry would cooperate and voluntarily offer to release minimally used codes. The Code Administrator should negotiate with code assignees to identify such codes for potential release and reassignment.

A.5.3 Conservation of signalling point code blocks

If the assignment of signalling point code blocks reaches the 90% level of available signalling point code blocks, then the first course of action would be to reserve an additional large network code. If the assignment of large network codes has reached the 80% level, then a large network code shall not be reserved. Instead an attempt shall be made to reclaim any unused or lightly used blocks assigned. It is expected that the industry would cooperate and voluntarily offer to release minimally used blocks. The Code Administrator should negotiate with code assignees to identify such codes for potential release and reassignment.

A.6 Code Administrator

The Code Administrator is given the full authority by T1 and the companies supporting T1 to carry out these guidelines. Contact the ATIS T1 Secretariat¹ to obtain the name and address of the current Code Administrator.

A.7 Interpretation of these guidelines

In order for signalling communications to occur between SS7 nodes, it is necessary for these nodes to be identified. This is true, regardless of the "nature" of the CCS network (e.g., "public" or "private"). Therefore, no restriction should be made based on the "nature" of the CCS network with respect to its eligibility for an SS7 code assignment.

¹ At T1 Secretariat, Alliance for Telecommunications Industry Solutions, 1200 G Street NW, Suite 500, Washington, DC 20005.

NOTE - Contact the Code Administrator for an Application Form.

SIGNALLING POINT CODE ASSIGNMENT RULES

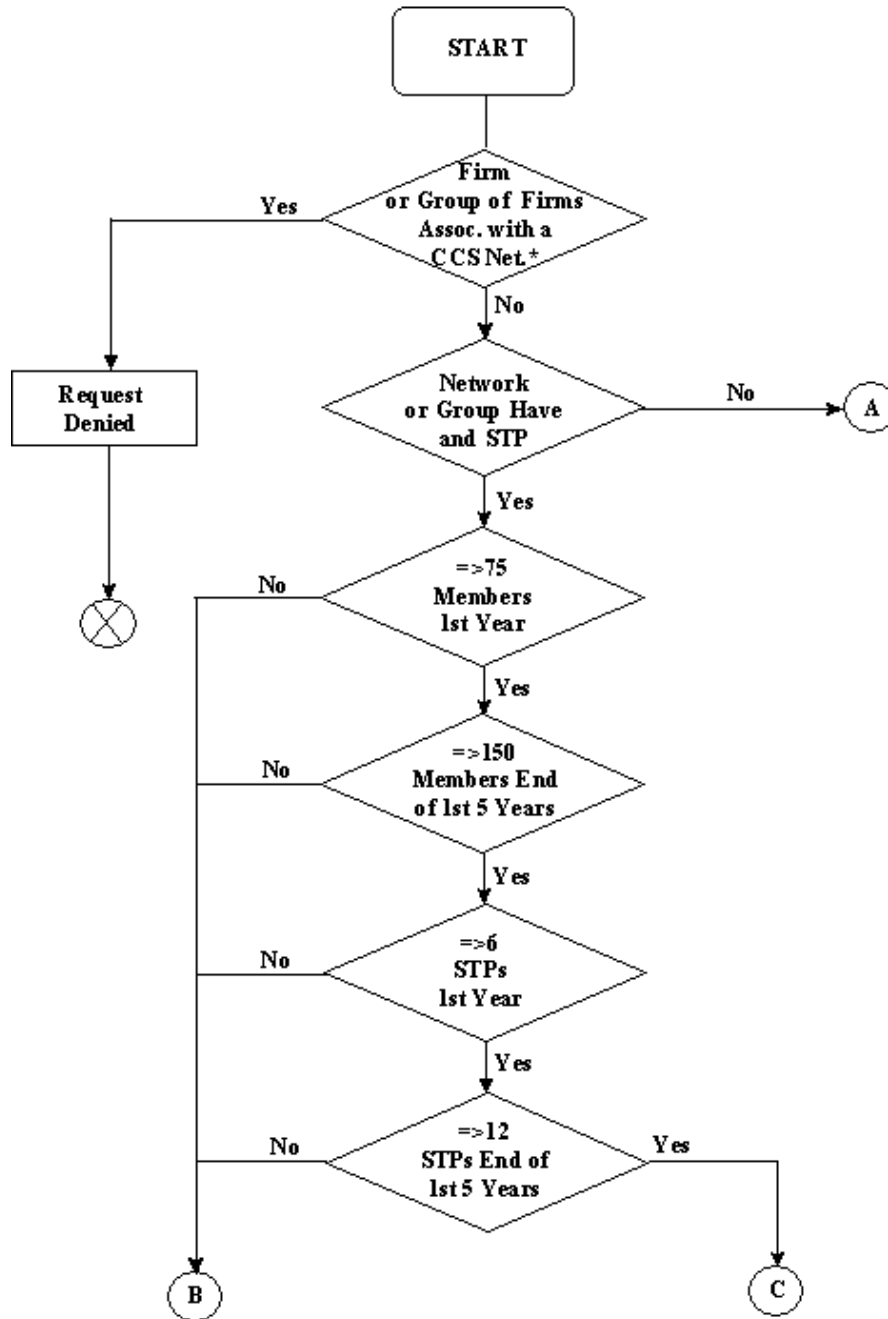

* NOTE - See Annex A, clause A.1

Figure A.1/T1.111.8 - Signalling point code assignment rules (sheet 1 of 4)

POINT CODE BLOCK

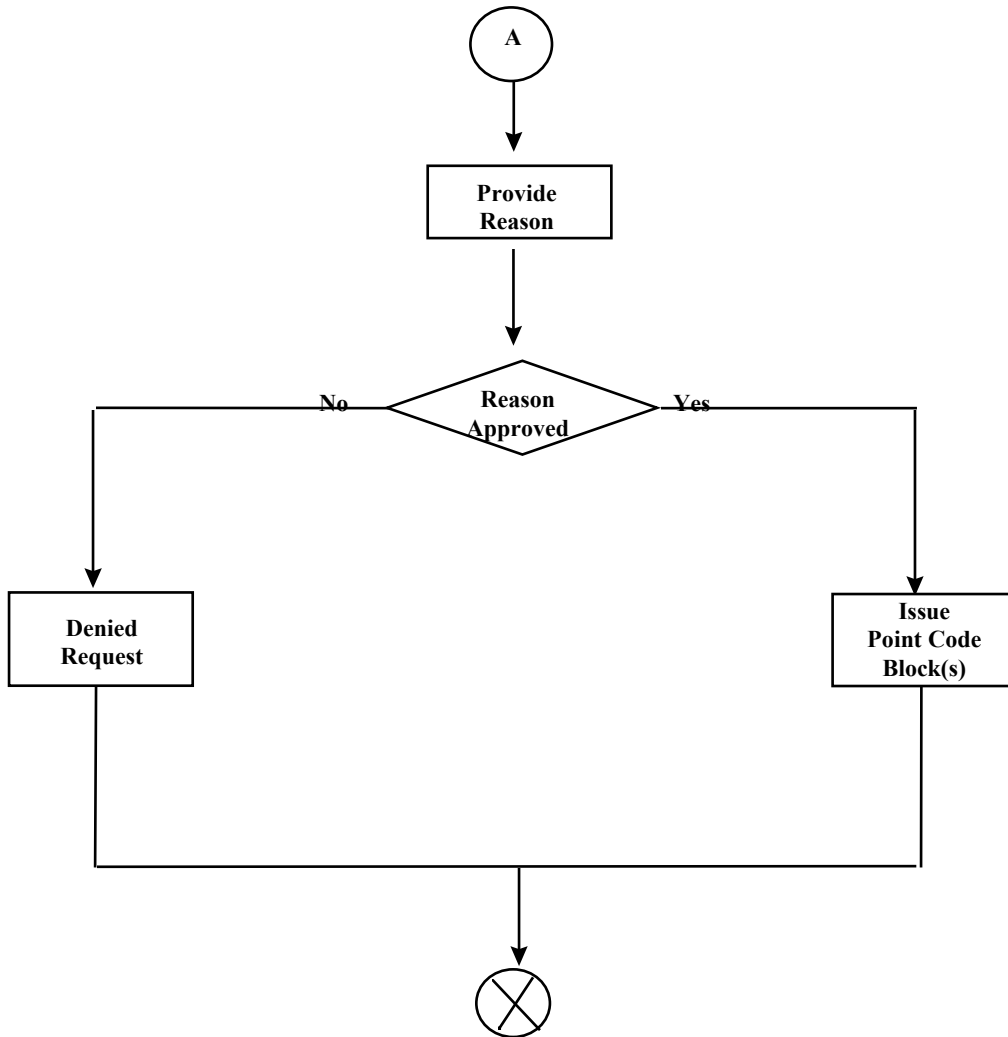

Figure A.1/T1.111.8 - Signalling point code assignment rules (sheet 2 of 4)

SMALL NETWORK CODE

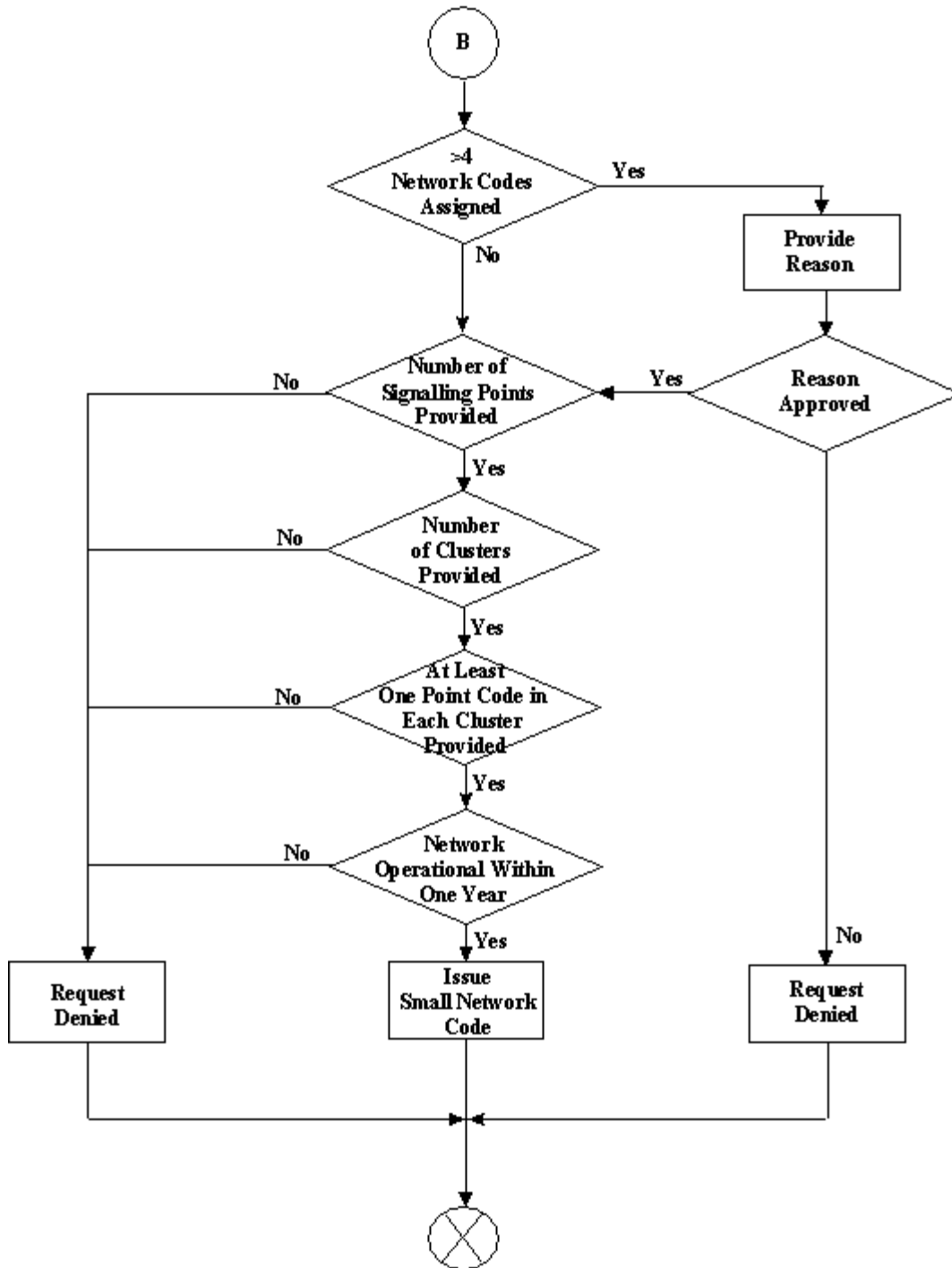

Figure A.1/T1.111.8 - Signalling Point Code Assignment Rules (sheet 3 of 4)

LARGE NETWORK CODE

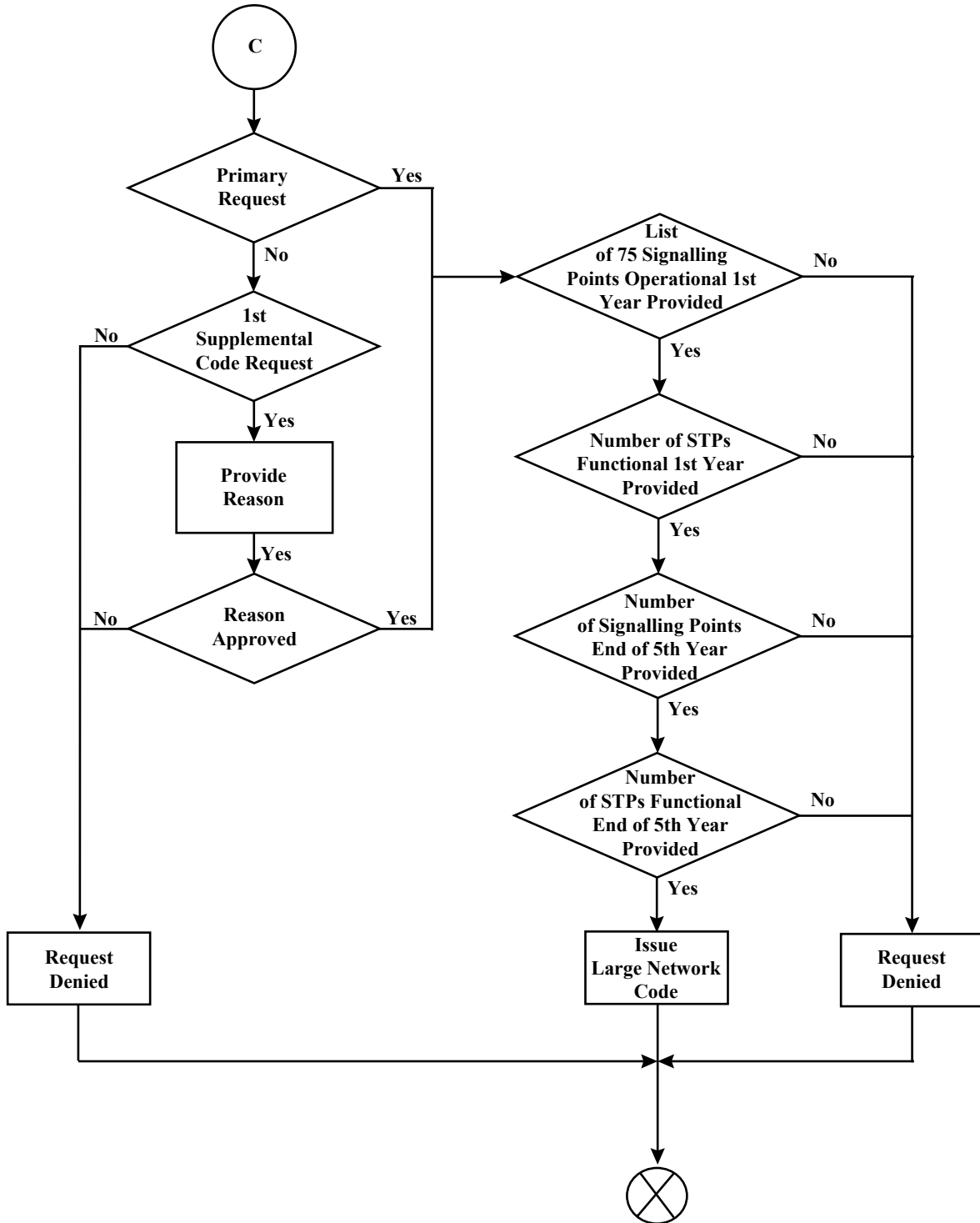

Figure A.1/T1.111.8 - Signalling Point Code Assignment Rules (sheet 4 of 4)